

Lighting up Tharparkar 2023

Technical Report

Installation of 300W Off-Grid Solar System in 30 Houses

Funded by Global Giving
Implemented by NHSD

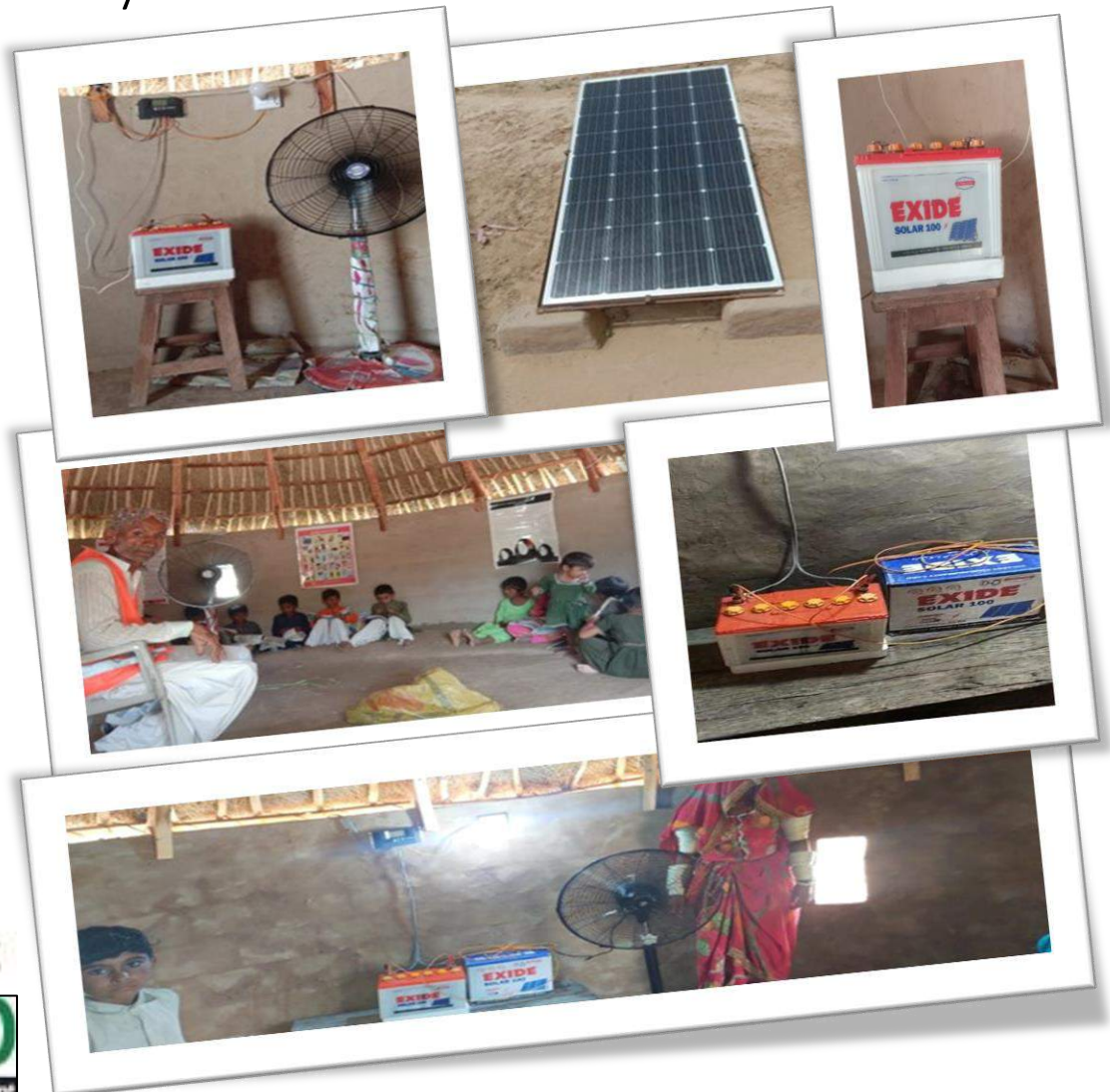

 GlobalGiving

 NHSD
Network for Human and Social Development

Introduction

Pakistan is a developing South Asian country facing massive economic, environmental, and social development challenges. These issues have led the country to an increased power demand. The country's total power demand is 25,000 Megawatts (MW), which by 2030 will boost up to 40,000 MW [1]. Unfortunately, the country's electricity supply remains around 17,000 MW, resulting in an electricity shortage of about 8000MW [2], because of which both urban and rural areas face 12 to 18 hours of shortfall a day [3]. The situation is much worse in rural parts of the Sindh province, where this fundamental human necessity remains inaccessible for many days. Many of the remote rural areas do not even have this facility. 48% of the population of the Sindh province lives in the rural region, and approximately 13,451 villages lack electricity facilities [4]. As these villages are spread near and far from the on-grid station, connection to the grid system is uneconomical and expensive and not a viable option. Areas like Mithrio Charran Tehsil (subdistrict), Chachro District, and Tharparkar are some rural areas in Sindh that do not have accessibility and have been devoid of electricity for at least 80 years. Like many rural areas in Sindh, the demand for electricity in Mithrio Charran is low, in contrast to urban areas, from only 50 Watts to 100 Watts per household [5]. Only a few lights and one to two fans are required because each house has only one room.

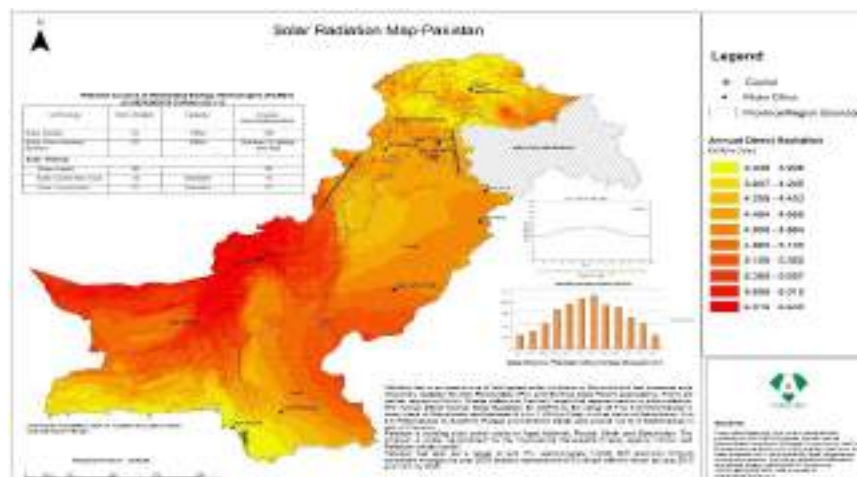

Figure-1. Solar Radiation Map of Pakistan [6]

Pakistan lies in one of the highest solar insolation areas of the world and has immense solar resources suitable for Photovoltaic (PV) Solar power applications.

Studies show that Pakistan has the potential of generating an estimated amount of 2900GW (Gigawatts) of power through only solar energy [7]; most of this generation can be facilitated by Sindh, as many of its regions receive a high amount of solar radiation throughout the year. Because of high solar irradiation, the province has enormous potential for solar energy, with more than 300 sunlight days and an estimated 1800-2200 kWh/m² (kilowatt hour per meter square) annual global horizontal irradiation [8]. Solar power applications are of three types, out of which off-grid solar energy is the best option for electrifying villages in the Sindh province.

Period	Daily Solar Irradiance (kWh/m ² /day)				
	Panoaqil Region	Badin Region	Nawabshah Region	Mirpurkhas Region	Kambar Region
Jan	4.10	4.49	4.20	4.41	3.73
Feb	4.97	5.25	5.09	5.06	4.89
Mar	5.71	5.97	5.76	5.88	5.83
Apr	6.65	6.69	6.67	6.61	6.90
May	6.88	6.79	6.90	6.78	6.79
Jun	6.76	6.48	6.75	6.55	6.77
Jul	5.91	5.08	5.82	5.52	5.65
Aug	5.97	5.14	5.91	5.49	6.00
Sep	5.86	5.47	5.82	5.58	5.82
Oct	4.95	4.97	5.03	5.00	5.47
Nov	4.00	4.31	4.13	4.15	4.22
Dec	3.70	4.02	3.80	3.90	3.68
Avg. annual values	5.45	5.39	5.49	5.41	5.48

Table-1. Solar data of five major regions of Sindh [9]

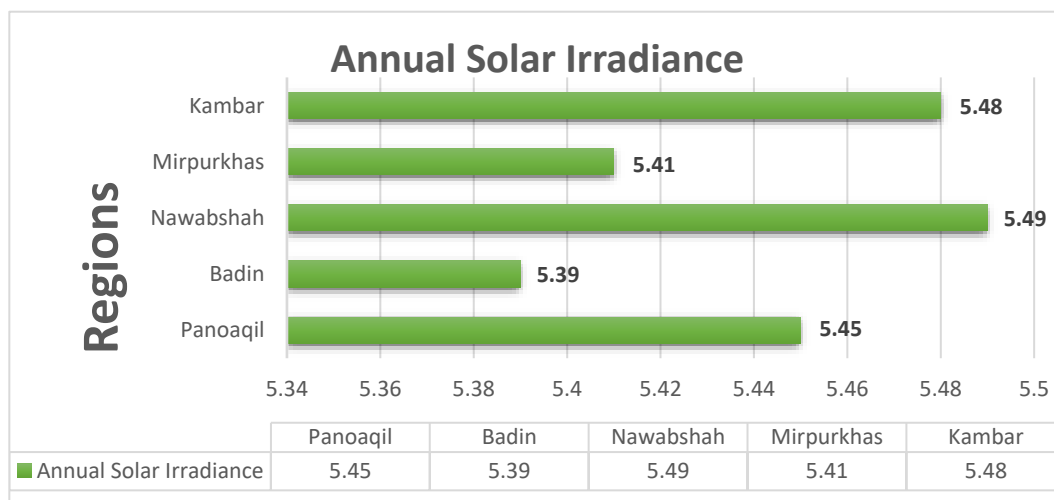

Figure-2. Annual solar irradiance received in five rural regions of Sindh.

The above solar dataset showcases why the Sindh region is the most viable option for installing solar electric systems. The daily solar irradiance received in all the five mentioned regions presents a potential to generate electricity from solar PV energy. Moreover, the average values of annual solar irradiance showcased in figure 2 illustrate that Nawabshah region receives the highest yearly solar irradiation (5.49 kWh/m²) followed by the Kambar region (5.48 kWh/m²), Panoaqil region (5.45 kWh/m²), Mirpurkhas region (5.41 kWh/m²), and the Badin region (5.39 kWh/m²), respectively. These favorable solar irradiance data provide a valid reason to invest in the solar system electrification of these regions for the betterment of the socioeconomic standards of people.

The Sindh province is rich in renewable energy (RE) sources, such as wind, solar, mini-hydro, and biomass, which are very viable for clean electricity generation. However, the government of Sindh has not taken serious steps to integrate RE resources into power generation despite the ever-increasing electricity demand. Although the government had planned a RE policy in 2006, it is still in the infancy stage due to the lack of interest by the government in exploiting these natural resources. Investors are worried and unwilling to invest in the remote rural regions of Sindh since a deteriorating law and order situation, nonexistent infrastructure, use of violence as a deterrence on institutional and societal change in Sindh, and a low return on investment are factors behind obstructing private investment. Recently, the World Bank announced to finance \$100 million worth of loans for installing clean energy in Sindh. The target is to provide off-grid solar PV electricity to 200,000 households, equal to 1.2 million people [10]. Due to poor planning and policies by the government, most of the installation of the solar system is done by non-profit organizations and NGOs both through national and international funding, whilst the funds allocated to the Sindh Provincial Government Development Fund are still not audited nor have they shown any willingness to provide transparent reporting.

Solar Electrification of 30 Houses

Considering all the above factors, Solar PV technology was considered the most appropriate option for providing electricity to 30 houses in Mithrio Charran because of the low-cost technology, easy installation, and being environmentally friendly. Each of the 30 houses has a 300W Off-grid solar system providing a continuous generation of electricity needed to run one 10W DC light bulb and 50W DC pedestal fan.

Design

As previously discussed, rural parts of Sindh need less power, which ranges between 50W to 100W per house. After doing the site visitation and consulting the families of the 30 homes built in Mithrio Charran, it was apparent that each family, at least, needs a light bulb and a fan that can run continuously during day and nighttime and also for the days when the weather is cloudy with little to no sunlight. Keeping all these things into consideration, each house has a 300W off-grid solar system providing a continuous generation of electricity needed for running one 10W DC light bulb and a 50W DC pedestal fan. The components used for the designing of the said solar system are as follows:

- Solar Panels
- Solar Panel Frames
- Charge controller
- Battery
- DC Appliances (light and fan)
- Cable and connecting wires
- Switch boards and buttons

Components	Technical Description	Quantity
Solar Panels	Tier-1 Mono Perc Solar Panels, 144 Cells A-Grade, LONGI (320W+)	30
Charge Controller	CM3024 12V/24V controller with PWM charging mode	30
Battery	Exide Solar 100, 12V 60Ah, Lead Acid Battery	30
Solar Panel Frames	Ground mounted L2 structures	30

Cables	Fast cables, DC cables standard size, 40 feet long	30
Switch Boards and buttons	AC and DC Disconnection switches	30
Tape	Insulation tape for DC cables	30
Auxiliary components	GI coated flexible duct/PVC/Pipes/ clamps	30
Pedestal Fan	50W DC GC Fan Pedestal Fan	30
Light Bulb	10W DC Light Bulb	30

Table-2. Components used in the design and installation of 300W off-grid solar system.

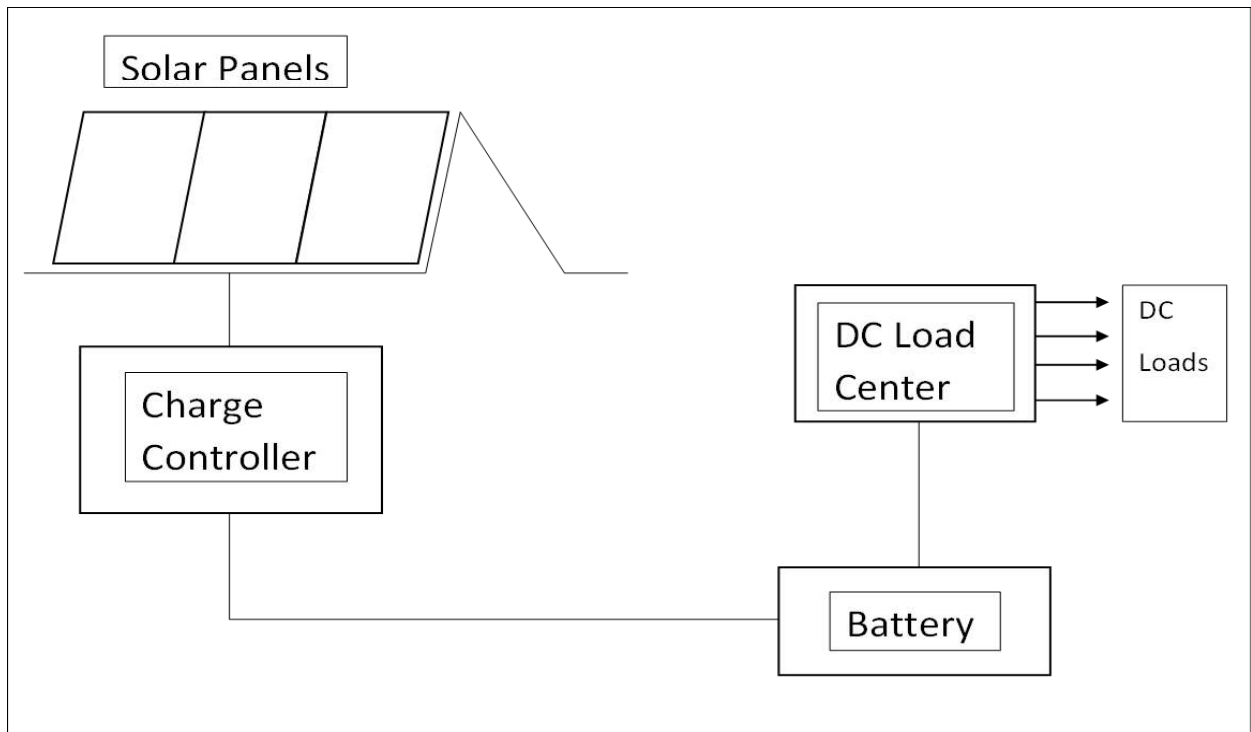

Figure-3. Schematic of an off-grid PV system with DC loads.

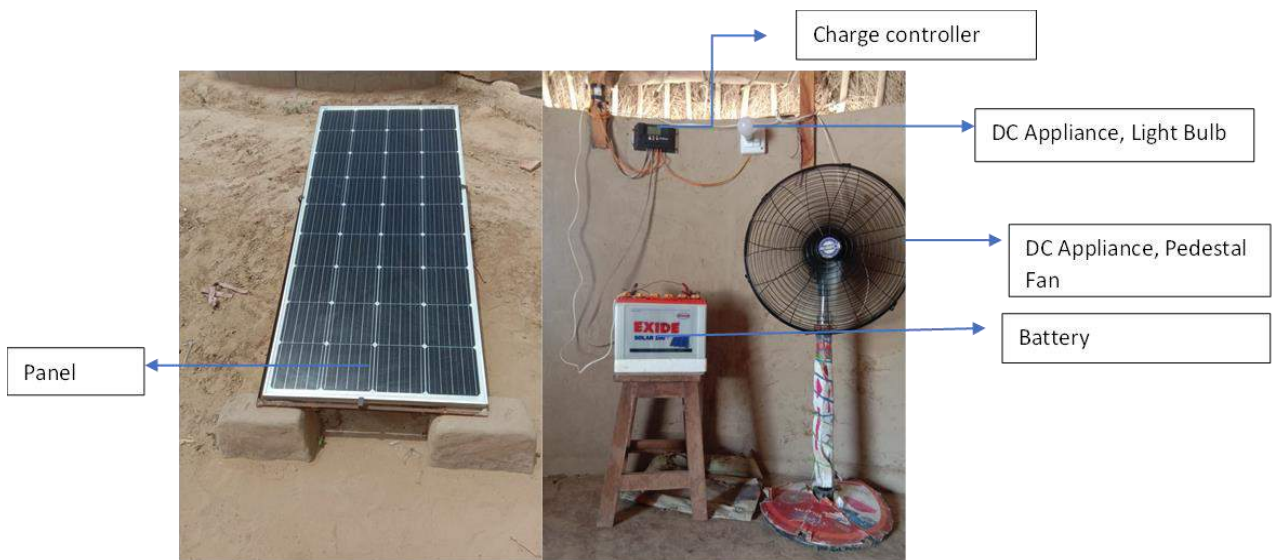

Figure-4. Schematic of an off-grid PV system with DC loads.

Component Selection

1. DC Appliances

Each house has two electric appliances, a 10W DC light bulb, and a 50W pedestal fan. As the load is DC (Direct current), no inverter is needed; this makes the designed solar system simplified and economical.



2. Solar Panels

Each house has one LONGI monoperc (Monocrystalline solar cells cut from a single piece of silicon) solar panel that provides a power of 300W to 320W. The solar panel is a monocrystalline technology which is expensive but has a high-power output, occupies less space, and lasts the longest. Its efficiency rate is one of the highest, about 20% (20% of the sunlight hitting the solar panel converts into DC current). Another advantage of using a monocrystalline panel is that it is more resistant to the effects of high temperatures. Hence, these panels are more suitable to work in the extreme temperature environment of Mithrio Charran. Installing a 300W to 320W panel minimizes the losses within the system and allows solar expansion for future projects.



3. Battery

Each house has one 12V, 60Ah, Lead-acid Exide battery for storing excessive power generated by solar panels for its usage during nighttime. The advantages of using lead acid are as follows:

Low-cost: One of the significant advantages of using this type of battery is it's cheap, thus making it an excellent



choice for installing small solar systems in remote rural areas without incurring substantial expense.

High reliability: The lead acid battery can work under intense temperatures and severe natural circumstances, thus making it an excellent option for storing energy in Mithrio Charran. This battery has a long-life span and can work up to two decades with adequate maintenance.

Easy to Maintain: Maintenance of battery is easy as it doesn't require special tools or technical expertise to keep it working correctly. Regular maintenance includes checking and adding distilled water in the battery cells, terminal cleanings, and ensuring proper battery charging.

High efficiency: The lead acid battery has a high-efficiency rate of 70% to 80% when storing solar energy.

Environmentally friendly: Unlike other batteries, lead-acid batteries are recyclable, making them environmentally more viable. When the battery reaches the end of its life, the lead and acid can be recycled and used to produce new batteries. Consequently, this minimizes wastage and aid in safeguarding the environment.



4. Charge Controller

One CM3024 12V Solar charger controller is used to regulate the voltage and current from the solar panel connected to the battery and prevent the overcharging of the batteries. It is a PWM (pulse width modulation) controller. Such controllers are cheap and best suited for small-scale applications like the one designed in Mithrio Charran because the solar panel system and batteries must have matching voltage, which is 12V in this case.

CM3024 controller works suitably with the selected Longi panels because for the controller to work properly, the panel's Voc (open circuit voltage) should be less than 50V, and the Voc of the Longi panel is around 40V.



5. Mounting Structure

Solar panel for each house is ground mounted. In this mounting, the installation of the panel is on the land. This type of mounting is chosen over roof mounting because these houses are thatched roofs and cannot bear the weight of the panels and thus can collapse. The area where the panels are installed is shadow-free and has direct exposure to sunlight, thus resulting in higher generation.



Because of ground mounting there is no need of house modification. It is easier to install and can accommodate higher capacity for future expansion. Although ground mount panels are more prone to vandalism and damage from extreme winds, cement blocks are used to avoid robbery and other calamities.

6. Consumables

Standard size 40-foot-long DC cables made up of copper are used for the connections in the solar system. Other miscellaneous products are installed in each house which includes one switchboard, one button, clamps, and insulation tapes for the cables and wires.

Maintenance

To ensure that the system operates efficiently, safely, and for a long period of time, solar panels must be cleaned and serviced every two months and two years, respectively. The most common way to clean solar panels is to spray them with water that washes away surface debris. Unfortunately, Mithrio Charran district doesn't have a running water system (dire funding is needed to establish a running water system). Servicing solar panels involves detailed electrical testing and a thorough visual inspection to ensure the nominal operations of the equipment and cables. Also, it is required to hire a licensed electrician to service solar systems as

they will know what to look for, will work safely, and be able to diagnose and fix any issues.

Pictures with Locations



<https://goo.gl/maps/WZpBQAkD5oXb3ySCA>



<https://goo.gl/maps/fBfLCcqSsTwSLWzE6>



<https://goo.gl/maps/fBfLCcqSsTwSLWzE6>



<https://goo.gl/maps/zaxdKipU1kxFyfAF9>



<https://goo.gl/maps/DXPQJnYTEB7QCvuv9>



<https://maps.google.com/?q=25.234071,70.491496&entry=gps>



<https://goo.gl/maps/yP2qxpVPsR3cMLt68>



<https://goo.gl/maps/F4L5HCBMTWjpG7Bs5>



<https://goo.gl/maps/WDH27ewWvw6cceVd8>



<https://goo.gl/maps/eu5ToqbPhKiT8fpY7>



<https://goo.gl/maps/G9K8xXwD1WTiavEu5>



<https://goo.gl/maps/cAx78avE97eAZN4k7>



<https://goo.gl/maps/W27sVnPGuwAofhWe6>



<https://goo.gl/maps/AMGNA55LZr3Z2632A>

Conclusion

Each thirty house has a 300W- off-grid solar panel system installed, which provides continuous electricity to its residents. As a result, the quality of livelihood of the residents of these houses has increased tremendously. However, more work needs to be done for the betterment of people, requiring more funding to provide continuous water source, maintenance of these solar systems, and extending this solar project to the rest of Mithrio Charran, Sindh.

References

1. Rehman, S.A.U.; Cai, Y.; Fazal, R.; Das Walasai, G.; Mirjat, N.H. An Integrated Modeling Approach for Forecasting Long-Term Energy Demand in Pakistan. *Energies* 2017, 10, 1868. [Google Scholar] [CrossRef]
2. Raheem, A.; Abbasi, S.A.; Memon, A.; Samo, S.R.; Taufiq-Yap, Y.H.; Danquah, M.K.; Harun, R. Renewable Energy Deployment to Combat Energy Crisis in Pakistan. *Energy Sustain. Soc.* 2016, 6, 16. [Google Scholar] [CrossRef]
3. Raheem, A.; Abbasi, S.A.; Memon, A.; Samo, S.R.; Taufiq-Yap, Y.H.; Danquah, M.K.; Harun, R. Renewable Energy Deployment to Combat Energy Crisis in Pakistan. *Energy Sustain. Soc.* 2016, 6, 16. [Google Scholar] [CrossRef]
4. Qayyum, S. Pakistan: A Renewable Energy State? Available online: <http://www.technologyreview.pk/pakistan-a-renewable-energy-state/> (accessed on 07 September 2023).
5. Qayyum, S. Pakistan: A Renewable Energy State? Available online: <http://www.technologyreview.pk/pakistan-a-renewable-energy-state/> (accessed on 07 September 2023).
6. <https://www.alhasan.com/maps/solar-radiation-map-pakistan>
7. Solangi, Y.A.; Tan, Q.; Mirjat, N.H.; Das Valasai, G.; Khan, M.W.A.; Ikram, M. An Integrated Delphi-AHP and Fuzzy TOPSIS Approach toward Ranking and

Selection of Renewable Energy Resources in Pakistan. Processes 2019, 7, 118. [Google Scholar] [CrossRef]

8. Wakeel, M.; Chen, B.; Jahangir, S. Overview of Energy Portfolio in Pakistan. Energy Procedia 2016, 88, 71–75. [Google Scholar] [CrossRef][Green Version]
9. NASA-POWER Project Data Sets. Available online: <https://power.larc.nasa.gov/> (accessed on 07 September 2023).
10. NASA-POWER Project Data Sets. Available online: <https://power.larc.nasa.gov/> (accessed on 07 September 2023).